



User Guide

UD51

Second encoder small option
module for Unidrive

Part Number: 0460-0084-05
Issue Number: 5

Safety Information

The option card and its associated drive are intended as components for professional incorporation into complete equipment or systems. If installed incorrectly the drive may present a safety hazard. The drive uses high voltages and currents, carries a high level of stored electrical energy, and is used to control mechanical equipment that can cause injury.

Close attention is required to the electrical installation and the system design to avoid hazards either in normal operation or in the event of equipment malfunction. System design, installation, commissioning and maintenance must be carried out by personnel who have the necessary training and experience. They must read this safety information and this Installation Guide carefully.

Careful consideration must be given to the functions of the drive and option card which might result in a hazard, either through their intended functions, e.g. auto-start, or through incorrect operation due to a fault or trip, e.g. stop/start, forward/reverse, maximum speed, loss of a communications link. In any application where a malfunction of the drive or option card could lead to damage, loss or injury, a risk analysis must be carried out, and where necessary, further measures taken to reduce the risk. To ensure mechanical safety, additional safety devices such as electro-mechanical interlocks may be required. The drive must not be used in a safety-critical application without additional high-integrity protection against hazards arising from a malfunction.

General Information

The manufacturer accepts no liability for any consequences resulting from inappropriate, negligent or incorrect installation or adjustment of the optional operating parameters of the equipment or from mismatching the drive with the motor.

The contents of this User Guide are believed to be correct at the time of printing. In the interests of a commitment to a policy of continuous development and improvement, the manufacturer reserves the right to change the specification of the product or its performance, or the contents of the User Guide, without notice.

All rights reserved. No part of this User Guide may be reproduced or transmitted in any form or by any means, electrical or mechanical including photocopying, recording or by any information storage or retrieval system, without permission in writing from the publisher.

Drive software version

This product is supplied with the latest version of user-interface and machine control software. If this product is to be used in a new or existing system with other Drives, there may be some differences between their software and the software in this product. These differences may cause this product to function differently. This may also apply to Drives returned from a Control Techniques Service Centre.

If there is any doubt, contact a Control Techniques Drive Centre.

Contents

1	Introduction	4
1.1	Main features of the UD51	4
2	Safety Information	5
2.1	Warnings, Cautions and Notes	5
2.2	Electrical safety - general warning	5
2.3	System design and safety of personnel	5
2.4	Environmental limits	6
2.5	Compliance with regulations	6
2.6	Motor	6
2.7	Adjusting parameters	6
3	Installing the UD51	7
4	Making Connections	9
4.1	Locations of the terminals	9
4.2	Functions of the terminals	10
5	Setting Up the UD51	12
5.1	Example configurations	12
5.2	Position control and digital lock	12
5.3	Output speed-reference	13
5.4	Encoder shaft position	14
5.5	Encoder outputs (terminals 49, 50, 52, 53)	14
5.6	Z marker-pulse outputs (terminals 54, 55)	14
5.7	Freeze inputs (terminals 54, 55)	17
5.8	Delay times	18
6	Related Parameters	19
6.1	Introduction	19
6.2	Programmable software	19
6.3	Parameter descriptions	21
Appendix A:	Specifications	25
A.1	Inputs (terminals 40, 41, 43, 44, 46, 47)	25
A.2	Outputs and combined inputs/outputs (terminals 49, 50, 52, 53, 54, 55)	25
A.3	Temperature and humidity	25
Appendix B:	Diagnostics	26
B.1	Trip codes	26

1 Introduction

1.1 Main features of the UD51

1.1.1 Applications

The UD51 Second encoder small option module has inputs that allow a second encoder to be connected to a Unidrive. The module also has simulated-encoder outputs.

The UD51 operates with standard quadrature encoders having up to 5000 lines per revolution, allowing a maximum operating frequency of 250 kHz, or from frequency and direction (F/D) signals up to 500kHz.

When used in a drive operating in either the Closed-loop Vector or Closed-loop Servo operating mode, the UD51 can perform the following:

- Give speed and position feedback for position control or digital lock
- Accept frequency and direction reference input signals

1.1.2 Simulated encoder outputs

The UD51 has simulated encoder outputs which normally use the second encoder as the source, but can be re configured to use the main encoder (Encoder 1) connected to the 15-way D-type on the drive as the source. These outputs produce quadrature AB signals corresponding to the line counts from the source encoder. Also, these outputs can be configured for frequency and direction signals.

1.1.3 Installation

The UD51 must be fitted in the small option module bay of the Unidrive.

All connections to the drive are made by a multi-way connector. Connections from external equipment are made by a plug-in 16-way screw-terminal block on the UD51.

2 Safety Information

2.1 Warnings, Cautions and Notes



A Warning contains information which is essential for avoiding a safety hazard.



A Caution contains information which is necessary for avoiding a risk of damage to the product or other equipment.

NOTE

A Note contains information which helps to ensure correct operation of the product.

2.2 Electrical safety - general warning

The voltages used in the drive can cause severe electrical shock and/or burns, and could be lethal. Extreme care is necessary at all times when working with or adjacent to the drive.

Specific warnings are given at the relevant places in this User Guide.

2.3 System design and safety of personnel

The drive is intended as a component for professional incorporation into complete equipment or a system. If installed incorrectly, the drive may present a safety hazard. The drive uses high voltage and currents, carries a high level of stored electrical energy, and is used to control equipment which can cause injury.

Close attention is required to the electrical installation and the system design to avoid hazards, either in normal operation or in the event of equipment malfunction. System design, installation, commissioning and maintenance must be carried out by personnel who have the necessary training and experience. They must read this safety information and this User Guide carefully.

The STOP function of the drive does not remove dangerous voltages from the output of the drive or from any external option unit.

Careful consideration must be given to the functions of the drive which might result in a hazard, either through their intended functions or through incorrect operation due to a fault.

In any application where a malfunction of the drive could lead to damage, loss or injury, a risk analysis must be carried out, and where necessary, further measures taken to reduce the risk.

The STOP and START controls or electrical inputs of the drive must not be

relied upon to ensure safety of personnel. If a safety hazard could exist from unexpected starting of the drive, an interlock that electrically isolates the drive from the AC supply must be installed to prevent the motor being inadvertently started.

To ensure mechanical safety, additional safety devices such as electro-mechanical interlocks and overspeed protection devices may be required. The drive must not be used in a safety critical application without additional high integrity protection against hazards arising from a malfunction.

Under certain conditions, the drive can suddenly discontinue control of the motor. If the load on the motor could cause the motor speed to be increased (e.g. in hoists and cranes), a separate method of braking and stopping must be used (e.g. a mechanical brake).

2.4 Environmental limits

Instructions in this User Guide regarding transport, storage, installation and use of the drive must be complied with, including the specified environmental limits. Drives must not be subjected to excessive physical force.

2.5 Compliance with regulations

The installer is responsible for complying with all relevant regulations, such as national wiring regulations, accident prevention regulations and electromagnetic compatibility (EMC) regulations. Particular attention must be given to the cross-sectional areas of conductors, the selection of fuses or other protection, and protective earth (ground) connections.

This User Guide contains instruction for achieving compliance with specific EMC standards.

Within the European Union, all machinery in which this product is used must comply with the following directives:

98/37/EC: Safety of machinery.

89/336/EEC: Electromagnetic Compatibility.

2.6 Motor

Ensure the motor is installed in accordance with the manufacturer's recommendations. Ensure the motor shaft is not exposed.

Standard squirrel cage induction motors are designed for single speed operation. If it is intended to use the capability of the drive to run a motor at speeds above its designed maximum, it is strongly recommended that the manufacturer is consulted first.

Low speeds may cause the motor to overheat because the cooling fan becomes less effective. The motor should be fitted with a protection thermistor. If necessary, an electric forced vent fan should be used.

2.7 Adjusting parameters

Some parameters have a profound effect on the operation of the drive. They must not be altered without careful consideration of the impact on the controlled system. Measures must be taken to prevent unwanted changes due to error or tampering.

3 Installing the UD51



Before using the following procedure, refer to the Warnings at the beginning of Chapter 3 Mechanical Installation in the Unidrive User Guide.

1. Before installing the UD51 in the Unidrive, ensure the AC supply has been disconnected from the drive for at least 10 minutes.
2. Check that the exterior of the UD51 is not damaged, and that the multi-way connector is free from dirt and debris. Do not install a damaged or dirty UD51 in the drive.
3. Remove the terminal cover from the drive (for removal instructions, see Installing the drive and RFI filter in Chapter 3 of the Unidrive User Guide).
4. Position the multi-way connector on the rear of the UD51 over the connector in the drive (see Figure 1), and press on the thumb pad to push the UD51 into place.
5. Re-fit the terminal cover to the drive.
6. Connect the AC supply to the drive.
7. Set Pr **0.00** at 149 to unlock security.
8. Check that Pr **16.01** is set at 2 to indicate that the module is fitted.
9. If the check in step 8 fails, perform the following:
 - Remove the AC supply from the drive.
 - Wait at least 10 minutes.
 - Remove the terminal cover.
 - Check that the UD51 is fully inserted.
 - Replace the terminal cover.
 - Re-apply the AC supply.
 - Check again that Pr **16.01** is set at 2.

Figure 3-1 Installing the UD51 in the Unidrive

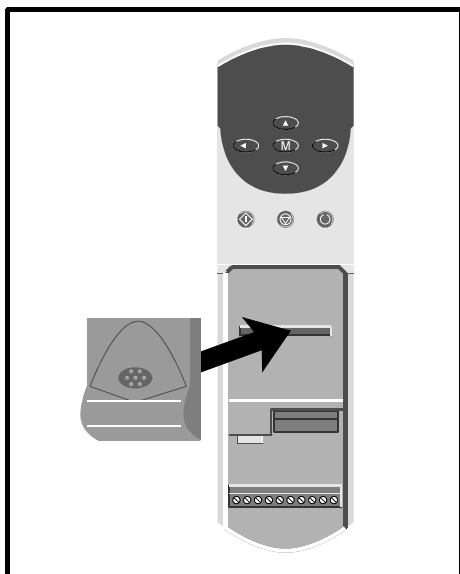

4 Making Connections



WARNING

The control circuits are isolated from the power circuits in the drive by basic insulation only, as specified in IEC664-1. The installer must ensure that the external control circuits are insulated from human contact by at least one layer of insulation rated for use at the AC supply voltage.

If the control circuits are to be connected to other circuits classified as Safety Extra Low Voltage (SELV) (eg. to a personal computer), an additional isolating barrier must be included in order to maintain the SELV classification.

4.1 Locations of the terminals

Figure 4-1 Location of the connector on the UD51

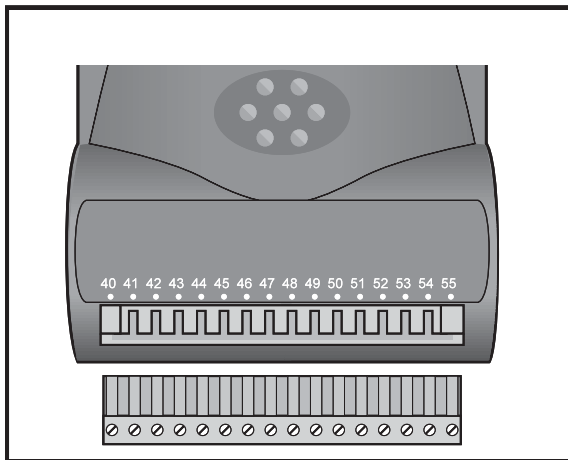

4.2 Functions of the terminals

All the I/O conforms to RS EIA485.

Terminal	Function
40	Quadrature channel A input (default) or F (frequency) input
41	Quadrature channel A\ input (default) or F\ (frequency\) input
42	0V
43	Quadrature channel B input (default) or D (direction) input
44	Quadrature channel B\ input (default) or D\ (direction\) input
45	0V
46	Marker pulse Z input
47	Marker pulse Z \ input
48	0V
49	Quadrature channel A output (default) or F (frequency) output
50	Quadrature channel A\ output (default) or F\ (frequency\) output
51	0V
52	Quadrature channel B output (default) or D (direction) output
53	Quadrature channel B\ output or D\ (direction\) output
54	Marker channel Z output (default) or Freeze input (see Note on page 11)
55	Marker channel Z\ output (default) or Freeze\ input (see Note on page 11)

Figure 4-2 Encoder connections to the UD51

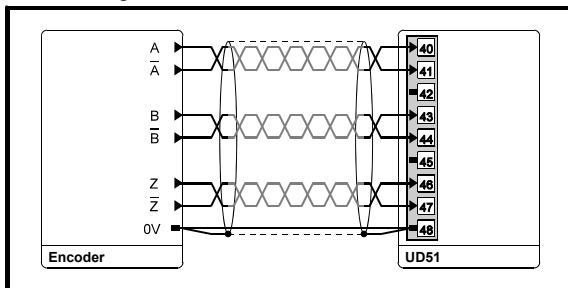

CAUTION

The encoder must be powered by an external DC supply. Ensure that the supply to be used is suitable for the encoder.

NOTE

The UD51 can be used with an encoder that does not produce Z marker pulses. In this case, ensure that the Z marker pulse inputs are left unconnected.

The Freeze input can be used only when the Z output is not used and is available only with the following versions:

UD51 version 3 onward

Drive software version 3 onwards

5 Setting Up the UD51

5.1 Example configurations

For both configurations, ensure the following:

The correct value is entered in Pr **16.04** No. of lines per revolution.

Pr **16.05** F/D input enable is set as appropriate.

5.2 Position control and digital lock

Main feedback: Quadrature encoder connected to the 15-way D-type connector in the drive

Reference signal: Connected to the UD51

The UD51 is used to supply a reference signal to the drive. This reference is applied to Menu 13 Position Control.

Signal format can be either quadrature AB or frequency and direction (F/D).

Refer to Menus 3, 13 and 16.

Figure 5-1

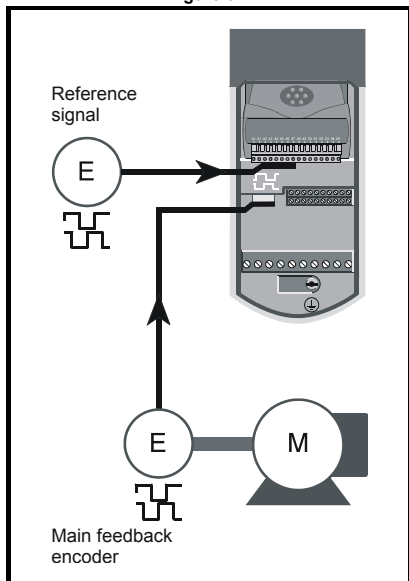

5.3 Output speed-reference

Reference output: From the UD51 to another drive or a controller

Main feedback: Quadrature encoder connected to the 15-way D-type connector in the drive

The UD51 can be used to supply a speed reference signal to another drive or to a controller

Signal format can be either quadrature AB or frequency and direction (F/D).

Refer to Menus 3 and 16.

Figure 5-2

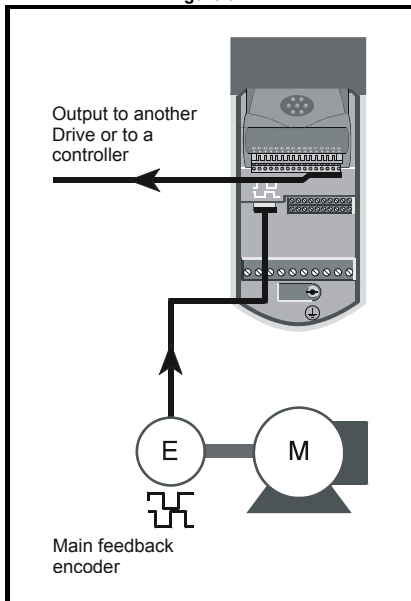

5.4 Encoder shaft position

The UD51 monitors the change in position of the encoder shaft by detecting the states of the quadrature A and B signals. Zero position is detected from the appropriate edge of the Z marker pulse, as follows:

Direction	Edge of the Z marker pulse
Forward	Rising
Reverse	Falling

5.5 Encoder outputs (terminals 49, 50, 52, 53)

The signal source and signal mode of these outputs can be selected as follows:

5.5.1 Signal source

Main or second encoder (see Pr 16.06 Encoder 1 select)

5.5.2 Signal mode

Quadrature AB signals or frequency and direction signals (see Pr 16.08 F/D output enable)

5.5.3 Scaling

To change the number of pulses per revolution for the output signals, see Pr 16.07 Encoder output scaling.

5.6 Z marker-pulse outputs (terminals 54, 55)

The simulated-encoder Z marker-pulse outputs are a buffered version of the Z marker-pulse inputs from the main encoder (Encoder 1) or the second encoder input.

The Z marker-pulse outputs are by default synchronized to the quadrant where the quadrature A and B signals are both low. When synchronization is disabled, the Z marker pulse can be present in any of the four quadrants, as follows:

- A and B both low
- A and B both high
- A low and B high
- A high and B low

5.6.1 Simulated Encoder Output - Marker

Whilst using a UD51, it is possible to synchronise the simulated encoder output quadrature signals to the marker output pulse. In order for the simulated encoder output to be synchronised the following hardware and software must be used

- A Unidrive with Software V03.01.07 or later
- An Issue 4 - UD51, 2nd Encoder Small Option Module

In order to synchronise the simulated encoder output signals to the marker output pulse the source encoder marker pulse must occur at the correct position with respect to the source encoder input signals A and B.

Also note Pr **16.12** the marker pulse output synchronisation disable, should be set to zero (default) enabling this (Pr **16.12** = 1) will result in the marker pulse output becoming present in any one of four quadrants.

Marker Output Pulse Position

The marker output pulse is derived from the same source as the simulated encoder outputs A and B.

The drive can ensure that the simulated encoder output signals A, A\ and B, B\ are produced so that the marker occurs whilst the A and B signals are low (A\ and B\ high) as shown in Figure 5-3.

Figure 5-3 Marker Pulse Active High

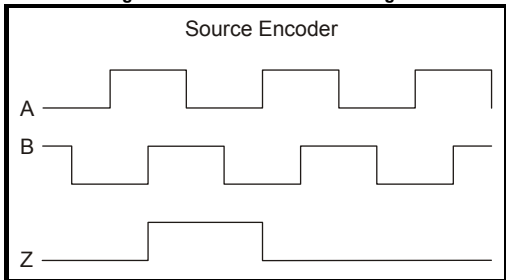

For the synchronisation to function the leading edge of the source encoder marker pulse must occur on the falling edge of signal B whilst signal A is low (as above).

If the source encoder provides a marker pulse when the A and B signals are high as shown below and a simulated encoder output is required with the synchronisation as detailed above, the wiring connections of the quadrature signals have to be modified as detailed in Figure 5-4.

Figure 5-4 Marker Active Pulse Low - A and B crossed with A\ and B

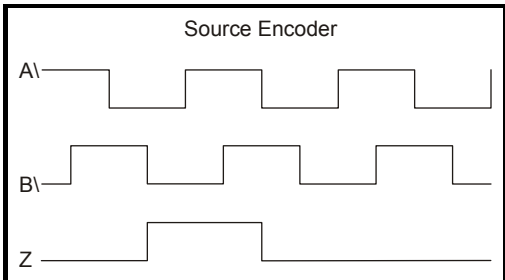

On the source encoder, A signal should be swapped with A\, and B signal with B\ as shown above. This will not change the direction of the feedback but will ensure correct synchronisation.

NOTE

From the above the simulated marker output will only be correctly synchronised when the source encoders marker pulse is active low. Active low being either as standard or by modifying the source encoder signal connections as detailed above.

The simulated marker output pulse function does not operate with F and D source encoders.

5.6.2 Drive software version V03.xx.07 onward, UD51 version 4 onward (both present)

Synchronization of the Z marker-pulse output can be disabled by setting Pr 16.12 Simulated-encoder output marker-pulse synchronization disable at 1. Synchronization is automatically disabled when Pr 16.07 Simulated-encoder output scaling is set at either of the following:

- At a value that would cause the resolution of the encoder-simulation outputs **not** to be an **integral number** of lines per revolution (LPR)
- At such a high value that the number of lines per revolution (LPR) of the simulated-encoder outputs is **less than 1**

Pr 16.13 Simulated-encoder Z marker-pulse outputs synchronization inactive indicator indicates the state of synchronization.

See the following logic table.

Pr 16.07	Pr 16.12	Synchronization	Pr 16.13
Set for integral number of LPR	0	Enabled	0
	1	Disabled	1
Set for no integral number of LPR Set for less than 1 LPR	0	Disabled	1
	1	Disabled	1

5.6.3 Drive software V03.xx.05 or earlier, UD51 version 3 or earlier (either or both present)

The Z marker-pulse outputs are synchronized to the simulated-encoder quadrature AB outputs only when the resolution of the AB outputs is equal to or greater than 1 LPR.

5.6.4 Drive software V03.xx.04 or earlier

Z marker-pulse synchronization cannot be disabled.

5.7 Freeze inputs (terminals 54, 55)

NOTE

The Freeze inputs are available only under the following conditions:

UD51 version 3 onward is fitted

Drive software V03.00.00 onward is present

UD70 Intelligent applications large option module (V2.06.00 or later) is fitted in the drive

Z marker-pulse outputs are not required

To use terminals 54 and 55 as Freeze inputs, set Pr **16.10** at 1. When a positive (differential) transition is applied, the position information of both the main encoder and the second encoder inputs is stored after a short delay. A similar delay will occur for both encoders.

The Freeze inputs are terminated by $120\Omega \pm 5\%$ (see Pr **16.11** Second encoder - Freeze input termination disable).

5.7.1 Related UD70 parameters

_Q20%.5	Control word (bit 5)
----------------	-----------------------------

Set at 1 for the current absolute positions of the feedback and reference encoders to be entered in **_Q21%** and **_Q22%** when the Freeze input is activated.

_Q20%.5 is reset to zero when the values have been entered.

_Q21%	Feedback-encoder freeze value
Units	Encoder lines
Range	-2^{31} to 2^{31}
Reset	H = S/V S = N/A P = N/A

_Q22%	Reference-encoder freeze value
Units	Encoder lines
Range	-2^{31} to 2^{31}
Reset	H = S/V S = N/A P = N/A

5.8 Delay times

Function	Delay time
Delay from input to output (main or second encoder) when operating in quadrature AB	1.5 μ s
Delay from Z input to Z output (main or second encoder)	1.5 μ s
Delay from Freeze input signal to storing of the position information	2 μ s
Difference in delay between storing the position information from the main encoder and the position information from the second encoder	250ns

6 Related Parameters

6.1 Introduction

The parameters listed in this chapter are used for programming and monitoring the UD51 when it is fitted in a drive. Refer to the Unidrive User Guide for programming instructions.



Before attempting to adjust any parameters, refer to the Warnings and Notes at the beginning of Chapter 4 electrical installation in the Unidrive User Guide.

6.2 Programmable software

6.2.1 Key

Type of parameter



RO Read-only



RW Read-write

...select Select from two settings

...enable Make or allow a function to operate

Limitations of use

P Protected parameter; the parameter cannot be used as the destination parameter for a programmable input.

Range

Bi Variable parameter having bipolar value range.

Uni Variable parameter having unipolar value range.

Bit Bit parameter

Symbols

⇒ Default value

⇕ Range of values

Figure 6-1 Logic diagram for the UD51

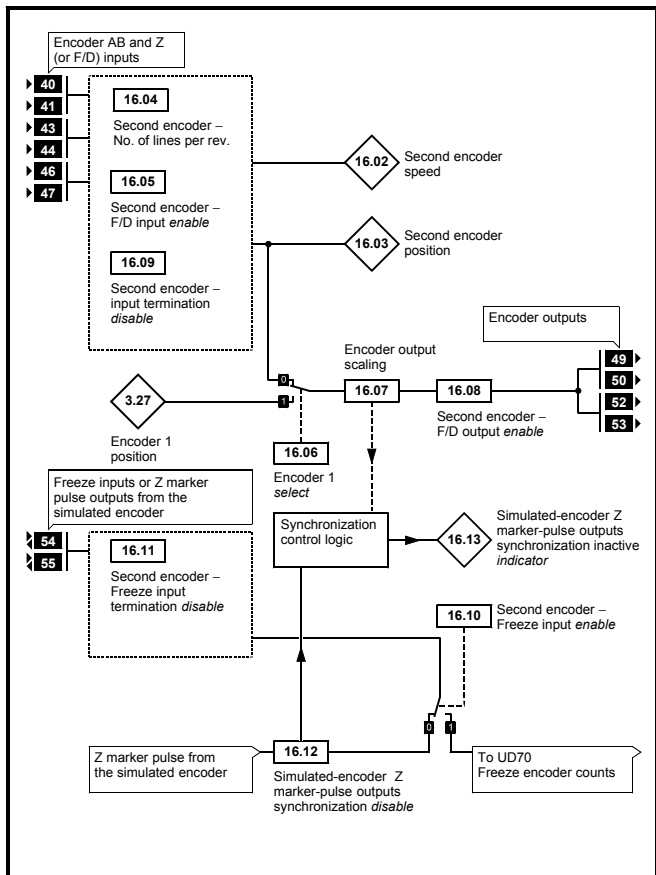

6.3 Parameter descriptions

Pr 16.01		Option module fitted code	
RO	Uni		P
↕	0 to 100	⇒	

16.01 indicates the type of small option module that is fitted in the drive, as follows:

- 0 No small option module
- 1 UD50 Additional I/O
- 2 UD51 Second encoder interface
- 3 UD53 Resolver interface
- 4 UD52 SIN-COS encoder interface

Pr 16.02		Second-encoder speed	
RO	Bi		P
↕	±30 000	⇒	

For Pr **16.02** to correctly indicate the speed of the second encoder, the correct value must be entered in Pr **16.04** Second encoder - No. of lines per revolution. Pr **16.05** Second encoder - F/D input enable must be set at 0.

Pr 16.03		Second-encoder position	
RO	Uni		P
↕	0 to 16384	⇒	Rev/16384

Pr **16.03** indicates the encoder shaft position counted from the point when the drive was last powered-up. If Z marker pulses have been detected, the position is indicated relative to the marker pulse. For Pr **16.03** to indicate correctly, the correct value must be entered in Pr **16.04** Second encoder - No. of lines per revolution

Pr 16.04		Second-encoder - No. of lines per revolution	
RW	Uni		
↕	0 to 10 000	⇒	1024 Lines/rev

Enter the number of lines per revolution of the encoder that is connected to the UD51. It is essential that the correct value is entered to ensure that Pr **16.02** Second encoder speed and Pr **16.03** Second encoder position indicate correctly. The values of these parameters are used in Menu 13 for position

control and for counting revolutions.

(For drive software versions V03.xx.05 and earlier, the range of this parameter was 0 ~ 8192.)

NOTE

Maximum number of encoder lines which can be set = AB - 5000 FD - 10,000
(16.05=1)

Pr 16.05		Second-encoder - F/D input enable	
RW	Bit		
⇅	0 or 1	⇒	0

Set as follows to select the required input mode for terminals 40, 41, 43, 44:

Pr 16.05	Input mode
0 (default)	Quadrature AB
1	Frequency and direction

Pr 16.06		Simulated-encoder output select	
RW	Bit		
⇅	0 or 1	⇒	0

Set as follows to select the source of the output signals for terminals 49, 50, 52, 53:

Pr 16.06	Source
0 (default)	Second encoder
1	Encoder connected to the 15-way D-type connector on the drive

Pr 16.07		Simulated-encoder output scaling	
RW	Uni		
⇅	0 to 15	⇒	0 (See below)

If the frequency of the output signals on terminals 49, 50, 52, 53 are required to be a fraction of the source signals, set Pr 16.07 at the required scaling factor as follows:

$$\text{Scaling} = 2^{[16.04]}$$

For example, for the output signals to be $1/16$ of the source, set Pr 16.07 at 4
($16 = 2^4$)

Pr 16.08		Simulated-encoder - F/D output enable	
RW	Bit		
↕	0 or 1	⇒	0

Set as follows to select the required output mode for terminals 49, 50, 52, 53:

Pr 16.08	Source
0 (default)	Quadrature AB
1	Frequency and direction

Pr 16.09		Second encoder - input termination disable	
RW	Bit		
↕	0 or 1	⇒	0

By default, 120Ω termination resistors are connected on the signal inputs. To disconnect these resistors, set Pr 16.09 at 1.

Pr 16.09 has no effect on the Freeze inputs. If required, see Pr 16.11 Second encoder - Freeze input termination disable.

Pr 16.10		Second encoder - Freeze inputs enable	
RW	Bit		
↕	0 or 1	⇒	0

Set as follows to select the required function of terminals 54 and 55:

Pr 16.10	Function of terminals 54, 55
0 (default)	Z marker - pulse output
1	Freeze input

Pr 16.11		Second encoder - Freeze inputs termination disable	
RW	Bit		
↕	0 or 1	⇒	0

By default, a 120Ω termination resistor is connected on the Freeze inputs. To disconnect this resistor, set Pr 16.11 at 1.

Pr 16.09 Second encoder - input termination disable has no effect on the Freeze inputs.

Pr 16.12		Simulated-encoder Z marker-pulse outputs synchronization inactive disable	
RW	Bit		
⇅	0 or 1	⇒	0

Use Pr 16.12 to control the setting of Pr 16.13 Simulated-encoder Z marker-pulse outputs synchronization inactive indicator.

Pr 16.13		Simulated-encoder Z marker-pulse outputs synchronization inactive indicator	
RW	Bit		
⇅	0 or 1	⇒	

Pr 16.13 indicates as follows:

Pr 16.13 set at 0

Z marker-pulses are synchronized to the quadrant where the quadrature A and B outputs are both low.

Pr 16.13 set at 1

Z marker-pulses can be present in any of the four quadrants, as follows:

- A and B both low
- A and B both high
- A low and B high
- A high and B low

See section 5.6 *Z marker-pulse outputs (terminals 54, 55)* on page 14.

Appendix A: Specifications

A.1 Inputs (terminals 40, 41, 43, 44, 46, 47)

Line loading	1 unit-load
Termination resistors (internal)	120 Ω \pm 5% See Pr 16.09 Second encoder - input termination disable
Maximum frequency	210 kHz (quadrature) 420 kHz (F and D)
Maximum applied voltage relative to OV	\pm 15V
Maximum applied differential voltage	\pm 25V

A.2 Outputs and combined inputs/outputs (terminals 49, 50, 52, 53, 54, 55)

Maximum frequency	210 kHz (quadrature) 420 kHz (F/D)
Absolute Maximum applied voltage	\pm 14V
Absolute Maximum output current	\pm 200mA
Protection	Current limit with thermal protection

A.3 Temperature and humidity

Ambient temperature range: 0°C to 50°C (32°F to 122°F)

Minimum temperature at power-up: -10°C (14°F)

Maximum humidity: 95% non-condensing at 40°C (104°F)

Storage temperature range: -40°C to 50°C (-40°F to 122°F)

Appendix B: Diagnostics

B.1 Trip codes

Lower display of the drive	No.	Conditions
SEP.diS	180	<p>The type of small option module that the drive has been programmed to operate with has been removed or is not fitted correctly.</p> <p>Perform either of the following:</p> <p>Ensure the appropriate type of small option module is correctly fitted</p> <p>To operate the drive in the present configuration, set Pr 00 at 1000 and press the STOP/RESET key.</p>