



*User Guide*

---

# **SM-CAN**

---

Solutions Module for  
Unidrive SP

Part Number: 0471-0023-02

Issue: 2

## **General Information**

The manufacturer accepts no liability for any consequences resulting from inappropriate, negligent or incorrect installation or adjustment of the optional operating parameters of the equipment or from mismatching the variable speed drive (Drive) with the motor.

The contents of this guide are believed to be correct at the time of printing. In the interests of a commitment to a policy of continuous development and improvement, the manufacturer reserves the right to change the specification of the product or its performance, or the contents of this guide, without notice.

All rights reserved. No parts of this guide may be reproduced or transmitted in any form or by any means, electrical or mechanical including photocopying, recording or by an information storage or retrieval system, without permission in writing from the publisher.

## **Drive software version**

The SM-CAN can only be used with Unidrive SP firmware version V1.00.00 and later.

Copyright    © January 2008 Control Techniques Drives Ltd.  
Issue:        2  
Firmware:    V0.01.00

---

# Contents

---

<b>1</b>	<b>Safety information</b>	<b>5</b>
1.1	Warnings, Cautions and Notes	5
1.2	Electrical safety - general warning	5
1.3	System design and safety of personnel	5
1.4	Environmental limits	6
1.5	Compliance with regulations	6
1.6	Motor	6
1.7	Adjusting parameters	6
<b>2</b>	<b>Introduction</b>	<b>7</b>
2.1	SM-CAN	7
2.2	General Specification	7
<b>3</b>	<b>Installing the Solutions Module</b>	<b>8</b>
3.1	General Installation	8
<b>4</b>	<b>Electrical installation</b>	<b>9</b>
4.1	SM-CAN terminal descriptions	9
4.2	SM-CAN connections	10
4.3	CAN cable	10
4.4	CAN network termination	11
4.5	SM-CAN cable shield connections	12
4.6	CAN ground point	13
4.7	SM-CAN back-up power supply	14
4.8	Maximum network length	14
<b>5</b>	<b>SM-CAN configuration</b>	<b>15</b>
5.1	SM-CAN node address	15
5.2	SM-CAN data rate	16
5.3	CAN network status	17
5.4	Resetting the SM-CAN	17
5.5	Storing SM-CAN configuration parameters	18
5.6	Reset all Solutions Modules	18
<b>6</b>	<b>SM-CAN commands</b>	<b>19</b>
6.1	CAN slot and slot addressing	19
6.2	SYPT version	19
6.3	PUTCAN	20
6.4	GETCAN	21
6.5	CANSTATUS	22
6.6	CANSTATUSALL	23
6.7	ENABLECANTRIPS	24
6.8	RESETCANTIMER	24
6.9	CANSETUP	25
6.10	CANGETNODEADDR	26
6.11	CANREADY	26
6.12	CANCONFIGEVENT	27

<b>7</b>	<b>Using the SM-CAN commands .....</b>	<b>28</b>
7.1	Configuring a CAN slot to receive messages .....	28
7.2	Transmitting a CAN frame .....	29
7.3	Receiving a CAN frame .....	30
7.4	Remote transmit request (RTR) .....	31
<b>8</b>	<b>Diagnostics .....</b>	<b>33</b>
8.1	Module ID code .....	33
8.2	SM-CAN firmware version .....	33
8.3	SM-CAN data rate .....	34
8.4	SM-CAN serial number .....	34
8.5	CAN network status .....	35
8.6	Drive trip display codes .....	35
8.7	SM-CAN error codes .....	36
<b>9</b>	<b>Advanced features .....</b>	<b>37</b>
9.1	Triggering SM-Applications event tasks .....	37
9.2	Restore SM-CAN defaults .....	37
9.3	Restore previous SM-CAN configuration .....	37
9.4	CAN slot over-write enable .....	38
<b>10</b>	<b>Quick reference .....</b>	<b>39</b>
10.1	Complete parameter reference .....	39

# 1 Safety information

## 1.1 Warnings, Cautions and Notes



A **Warning** contains information, which is essential for avoiding a safety hazard.



A **Caution** contains information, which is necessary for avoiding a risk of damage to the product or other equipment.

**NOTE** A **Note** contains information, which helps to ensure correct operation of the product.

## 1.2 Electrical safety - general warning

The voltages used in the drive can cause severe electrical shock and/or burns, and could be lethal. Extreme care is necessary at all times when working with or adjacent to the drive.

Specific warnings are given at the relevant places in this User Guide.

## 1.3 System design and safety of personnel

The drive is intended as a component for professional incorporation into complete equipment or a system. If installed incorrectly, the drive may present a safety hazard.

The drive uses high voltages and currents, carries a high level of stored electrical energy, and is used to control equipment which can cause injury.

Close attention is required to the electrical installation and the system design to avoid hazards, either in normal operation or in the event of equipment malfunction. System design, installation, commissioning / start up and maintenance must be carried out by personnel who have the necessary training and experience. They must read this safety information and this User Guide carefully.

The STOP and SAFE TORQUE OFF (SECURE DISABLE) functions of the drive do not isolate dangerous voltages from the output of the drive or from any external option unit. The supply must be disconnected by an approved electrical isolation device before gaining access to the electrical connections.

**With the sole exception of the SAFE TORQUE OFF (SECURE DISABLE) function, none of the drive functions must be used to ensure safety of personnel, i.e. they must not be used for safety-related functions.**

The SAFE TORQUE OFF (SECURE DISABLE) function and secure input on Unidrive SP and the SAFE TORQUE OFF (SECURE DISABLE) function of the Digitax ST meet the requirements of EN954-1 category 3 for the prevention of unexpected starting of the drive. They may be used in a safety-related application. **The system designer is responsible for ensuring that the complete system is safe and designed correctly according to the relevant safety standards.**

Careful consideration must be given to the functions of the drive which might result in a hazard, either through their intended behaviour or through incorrect operation due to a fault. In any application where a malfunction of the drive or its control system could lead to or allow damage, loss or injury, a risk analysis must be carried out, and where

necessary, further measures taken to reduce the risk - for example, an over-speed protection device in case of failure of the speed control, or a fail-safe mechanical brake in case of loss of motor braking.

## 1.4 Environmental limits

Instructions in the appropriate drive manual regarding transport, storage, installation and use of the drive must be complied with, including the specified environmental limits. Drives must not be subjected to excessive physical force.

## 1.5 Compliance with regulations

The installer is responsible for complying with all relevant regulations, such as national wiring regulations, accident prevention regulations and electromagnetic compatibility (EMC) regulations. Particular attention must be given to the cross-sectional areas of conductors, the selection of fuses or other protection, and protective ground connections.

The appropriate drive manual contains instruction for achieving compliance with specific EMC standards.

Within the European Union, all machinery in which this product is used must comply with the following directives:

98/37/EC: Safety of machinery.

89/336/EEC: Electromagnetic Compatibility.

## 1.6 Motor

Ensure the motor is installed in accordance with the manufacturer's recommendations. Ensure the motor shaft is not exposed.

Standard squirrel cage induction motors are designed for single speed operation. If it is intended to use the capability of the drive to run a motor at speeds above its designed maximum, it is strongly recommended that the manufacturer is consulted first.

Low speeds may cause the motor to overheat because the cooling fan becomes less effective. The motor should be installed with a protection thermistor. If necessary, an electric forced vent fan should be used.

The values of the motor parameters set in the drive affect the protection of the motor. The default values in the drive should not be relied upon.

It is essential that the correct value is entered in parameter **0.46** motor rated current. This affects the thermal protection of the motor.

## 1.7 Adjusting parameters

Some parameters have a profound effect on the operation of the drive. They must not be altered without careful consideration of the impact on the controlled system.

Measures must be taken to prevent unwanted changes due to error or tampering.

## 2 Introduction

**NOTE** Drive parameters are denoted in this manual by “Pr **MM.PP**”, where MM refers to the menu number, and PP refers to the parameter number within that menu. Please refer to the drive manual for full parameter definitions.

### 2.1 SM-CAN

The SM-CAN is an solutions module that can be installed to any one of the three expansion slots in the drive. The SM-CAN module uses a 16-bit processor and communicates at up to 1.0 Mbit/s, currently the fastest data rate available for CAN.

**Figure 2-1 Unidrive SP solution module**

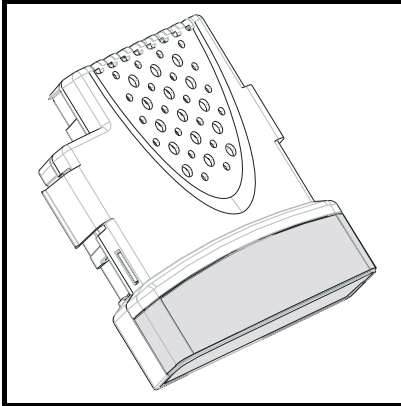

The SM-CAN module is powered from the drive's internal power supply. The drive can be connected to a back-up power supply. This keeps the control electronics and option modules powered up, allowing the SM-CAN module to continue communicating with the CAN master controller when the main supply to the drive is switched off.

SM-CAN can only be used if an SM-Applications is installed in another slot on the drive. The SM-Applications must contain system file V1.02.00 or later, and the Function Block Library in SYPT must also be V1.02.00 or later.

### 2.2 General Specification

- CAN 2.0 Part B passive (11-bit identifiers only)
- 14 transmit/receive CAN slots plus 1 receive only CAN slot
- Data rates supported: 1M, 800K, 500K, 250K, 125K, 100K, 50K, 20K, 10K
- Auto-detection of network data rate
- 3 separate event task trigger links to SM-Applications event tasks
- Full RTR message support

**NOTE** SM-CAN requires a second processor such as SM-Applications to allow operation of the CAN bus.

## 3 Installing the Solutions Module



Before installing or removing a Solutions Module in any drive, ensure the AC supply has been disconnected for at least 10 minutes and refer to Chapter 1 *Safety information* on page 5. If using a DC bus supply ensure this is fully discharged before working on any drive or Solutions Module.

### 3.1 General Installation

The installation of a Solutions Module is illustrated in Figure 3-1.

**Figure 3-1 Fitting a Solutions Module**

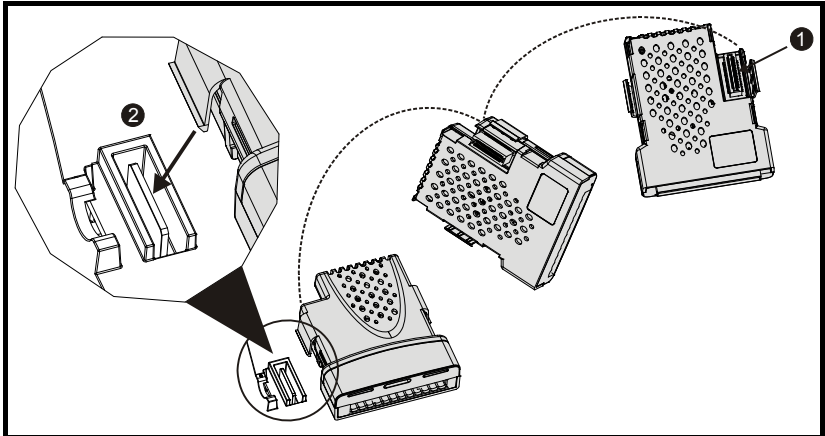

The Solutions Module connector is located on the underside of the module (1). Push this into the Solutions Module slot located on the drive until it clicks into place (2). Note that some drives require a protective tab to be removed from the Solutions Module slot. For further information, refer to the appropriate drive manual.



## 4 Electrical installation

### 4.1 SM-CAN terminal descriptions

The SM-CAN module has a 9-way D-type connector and a 5-way screw terminal block connector. Either terminal connector can be used for the CAN network connections.

**Figure 4-1 SM-CAN**

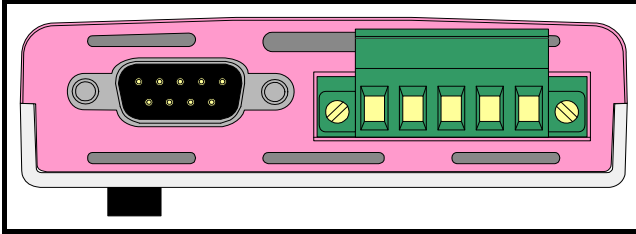

The connections for the CAN connectors are given in the table below.

**Table 4.1 SM-CAN connections**

D-type connector	5-way connector	Function	Description
6	1	0V EXTERNAL	0V CAN external supply (optional)
2	2	CAN-L	Negative data line
3, 5, Shell	3	Shield	Cable braided shield connection
7	4	CAN-H	Positive data line
9	5	+24V EXTERNAL	+24V CAN external supply (optional)

## 4.2 SM-CAN connections

The SM-CAN may be connected to the CAN network using the 9-way D-type connector or the 5-way screw terminal connector (See Figure 4-2). The length of the "pigtail" shield connection should be kept as short as possible.

**Figure 4-2 SM-CAN connections using 5 way connector**

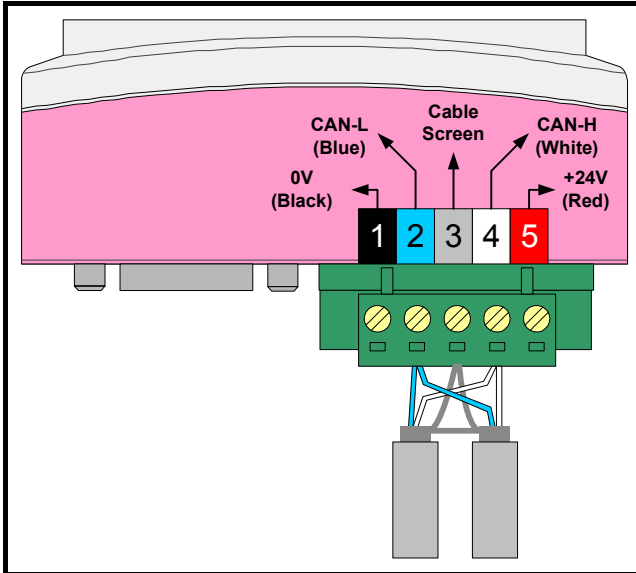

## 4.3 CAN cable

CAN cable requires a single twisted pair with overall shielding for the data wires. A second twisted pair may be used for a network power supply if required. The data wires are usually white and blue in cable designed for use in CAN networks.

**Table 4.2 CAN color codes**

Cable	Data signal	Terminal	Description
Blue	CAN-L	2	Negative data line
Braided Shield	Shield	3	Cable shield
White	CAN-H	4	Positive data line

CAN networks run at high data rates, and require cable specifically designed to carry high frequency signals. Low quality cable will attenuate the signals, and may render the signal unreadable for the other nodes on the network.

**NOTE** Ensure only approved CAN cable is used.

## 4.4 CAN network termination

The CAN network must be terminated at each end by fitting a  $120\Omega$  termination resistor between the CAN-H and CAN-L lines. This prevents signals from being reflected back down the cable and interfering with each other.

**Figure 4-3 Network termination**

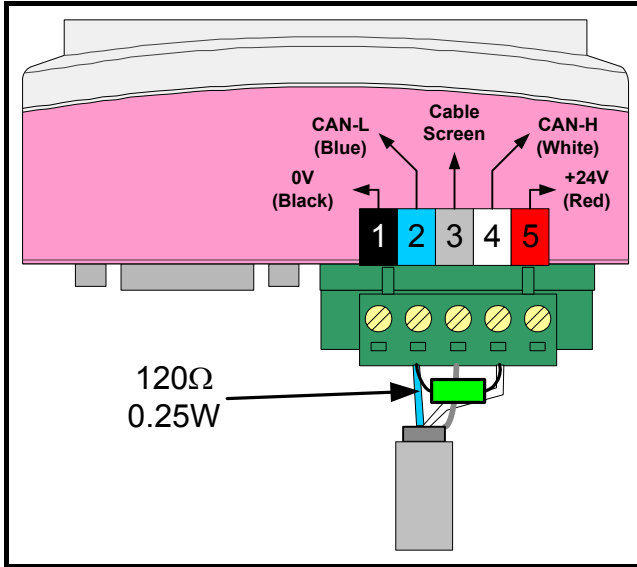

**NOTE** Failure to terminate a network correctly can seriously affect the operation of the network. If termination is not installed, the noise immunity of the network is greatly reduced, while if too many termination resistors are installed, the network will be over-loaded and may not operate at all.

Safety Information
Introduction
Installing the Solutions Module
<b>Electrical Installation</b>
SM-CAN configuration
SM-CAN commands
Using the SM-CAN commands
Diagnostics
Advanced features
Quick reference
Index

## 4.5 SM-CAN cable shield connections

The SM-CAN should be wired with the cable shields isolated from ground at each drive. The cable shields should be linked together at the point where they emerge from the cable, and formed into a short pigtail to be connected to pin 3 on the CAN connector.

**Figure 4-4 SM-CAN cable shield connections**

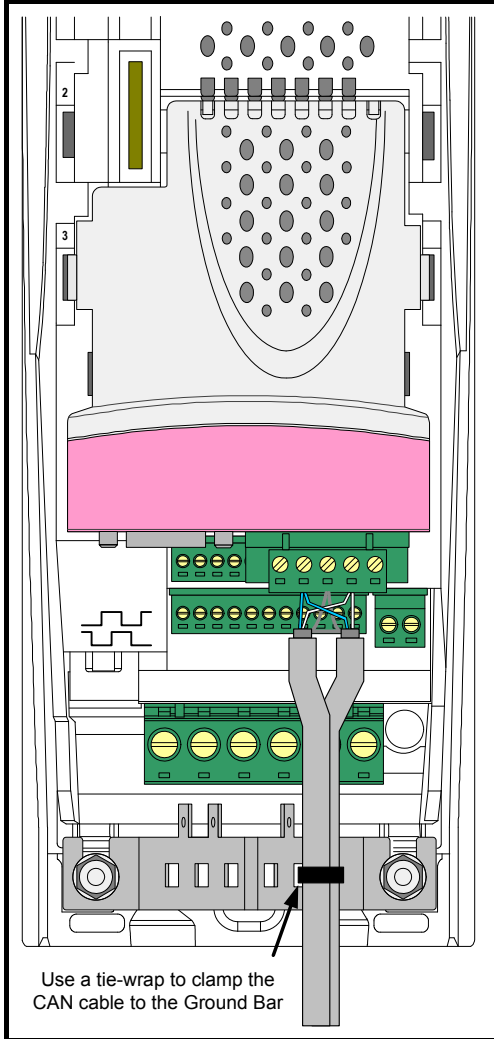

**NOTE** The CAN cable shield should be grounded at one place **ONLY** in the network, to prevent it from becoming live in the unlikely event of a major fault in one of the CAN devices. The shield can be grounded by exposing the braid shield and clamping it to the EMC clamp on a drive.

## 4.6 CAN ground point

The CAN cable shield must be grounded AT ONE POINT only, usually near the centre point of the cable run. This is to prevent the cable shield from becoming live in the event of catastrophic failure of another device on the CAN network.

If a drive node is the desired ground point, the shield of one of the CAN cables can be exposed and clamped to the Grounding Bar, as shown in Figure 4-5 below.

**Figure 4-5 SM-CAN ground point**

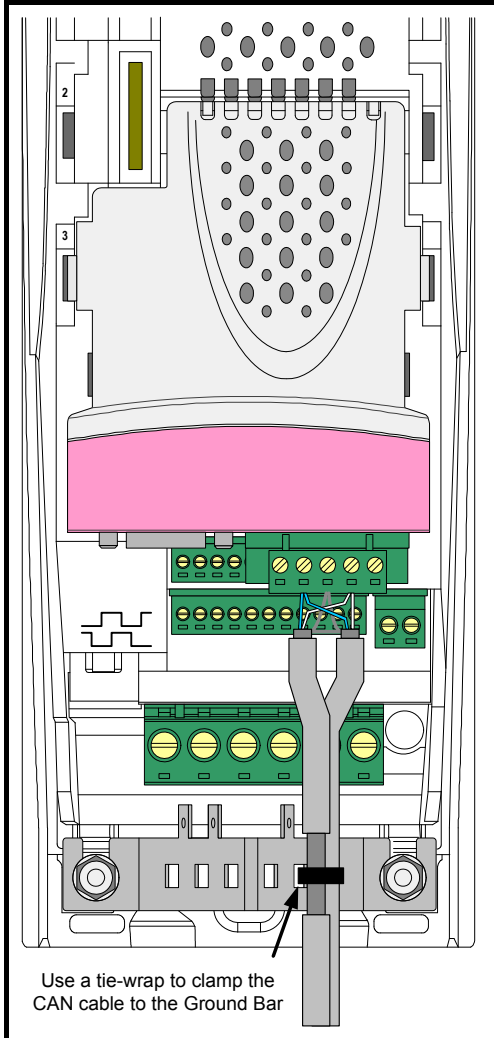

## 4.7 SM-CAN back-up power supply

If the CAN network is required to continue operating in the event of a loss of the main supply to the drive, a back-up +24V power supply should be connected to the drive. All option modules draw their power from the drive's internal power supply, and this will guarantee that the SM-CAN will continue to communicate.

The external power supply pins on the SM-CAN connectors will NOT keep the SM-CAN module powered up. These pins will only supply power to the CAN transceiver circuitry, and the maximum current drawn is 10mA.

## 4.8 Maximum network length

The maximum number of nodes that can be connected to a single CAN network segment is 32 nodes. Repeaters may be used to increase the number of nodes on a network to a maximum of 127. The maximum network length depends on the specified data rate.

**Table 4.3 Maximum network lengths**

Data rate (bits/sec)	Maximum bus length (m)
10K	5000
20K	2500
50K	1000
100K	800
125K	500
250K	250
500K	100
800K	50
1.0M	30

# 5 SM-CAN configuration

**NOTE** The drive must be installed with firmware V1.00.00 or later for use with the SM-CAN.

The drive has 3 slots available for option modules, and each slot has a dedicated menu of configuration parameters.

**Figure 5-1 Drive slot arrangement**

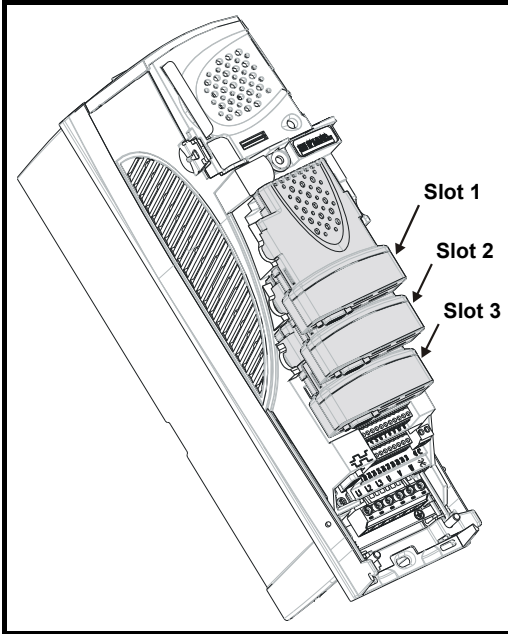

The SM-CAN can be installed to any slot, and each slot has a corresponding menu of parameters. When referring to a specific parameter for any slot, e.g. module ID code, the parameter will be referred to as Pr **MM.01**.

**Table 5.1 Slot configuration menu**

Slot	Menu
1	Pr 15.PP
2	Pr 16.PP
3	Pr 17.PP

## 5.1 SM-CAN node address

Name	SM-CAN node address		
Slot 1	Pr 15.03	Default	0
Slot 2	Pr 16.03	Range	0 to 127
Slot 3	Pr 17.03	Access	RW

Pr **MM.03** has been reserved for use as the node address parameter when a CAN protocol is implemented in the SM-Applications.

**NOTE**

SM-CAN requires the use of a second processor such as SM-Applications to communicate on the CAN bus.

## 5.2 SM-CAN data rate

Name	SM-CAN data rate		
Slot 1	Pr 15.04	Default	-2
Slot 2	Pr 16.04	Range	-2 to 8
Slot 3	Pr 17.04	Access	RW

Every node on a CAN network must be configured to run at the network data rate. If a node is configured with the wrong data rate, it may cause errors on the CAN network, and eventually trip on “SLx.Er” with error code 66 in Pr **MM.50** (Refer to section 8.7 *SM-CAN error codes* on page 36). The SM-CAN must be reset to make a change of data rate take effect. If an invalid data rate is set, the SM-CAN will reject the configured data rate and revert to the default setting.

**Table 5.2 SM-CAN data rates**

Pr MM.04	bits/s	Pr MM.04	bits/s
-2	Disabled	4	125K
-1	Auto	5	100K
0	1.0M	6	50K
1	800K	7	20K
2	500K	8	10K
3	250K		

The SM-CAN can automatically detect the network data rate by setting Pr **MM.04** to -1. SM-CAN will monitor the CAN network, and if the data rate is detected, it will set Pr **MM.04** to the indicate the detected data rate. However, it should be noted that the new value of Pr **MM.04** will NOT be stored.

The recommended sequence of events using auto-detection of the data rate as follows:

1. Power up the drive.
2. Set Pr **MM.04** to -1
3. Reset the SM-CAN by setting Pr **MM.32** to ON.
4. Connect the SM-CAN to the CAN network.
5. Wait for Pr **MM.04** to change from -1.
6. Store the drive parameters by setting Pr **MM.00** to 1000 and pressing RESET.

**NOTE**

The SM-CAN may have problems detecting the network data rate if there is little traffic on the CAN network. Auto-detection of the data rate is ideal when connecting a new node to an existing network, but may not work reliably if a network is powered up with all nodes attempting to detect the network data rate.

SM-CAN can also be disabled completely by setting Pr **MM.04** to -2. This ensures that a new default SM-CAN will not interfere with an existing network until it has been configured and enabled.



## 5.3 CAN network status

Name	CAN network status		
Slot 1	Pr 15.06	Default	N/A
Slot 2	Pr 16.06	Range	-10 to 9999
Slot 3	Pr 17.06	Access	RO

Network activity can be monitored in the CAN network status parameter, Pr **MM.06**. When the SM-CAN is communicating successfully with the CAN master controller, the CAN network status parameter will give an indication of the number of CAN frames received or transmitted every second.

**Table 5.3 CAN network status codes**

Pr MM.06	Parameter	Description
>=0	Network ok	Indicates the number of CAN frames transmitted or received every second
-1	Initialised	No message acknowledgement received. Indicates that there are bad wiring connections on the network, or that SM-CAN is the only node currently active on the CAN network
-2	Internal hardware failure	Part of the SM-CAN initialisation sequence was not successful. If this fault persists after a power cycle, replace the SM-CAN.
-3	Configuration error	There is an invalid setting in the SM-CAN configuration parameters
-4	Internal software error	Indicates that an internal software error has occurred. If this fault persists after a power cycle, replace the SM-CAN
-8	Auto data-rate detect	SM-CAN is currently attempting to automatically detect the network data rate
-10	Bus off error	SM-CAN has detected an excessive number of transmission errors and has entered the bus off condition

If a configuration error or network error is detected, the drive may trip. Refer to section 8.6 *Drive trip display codes* on page 35 for details about the drive trip display.

## 5.4 Resetting the SM-CAN

Name	SM-CAN reset		
Slot 1	Pr 15.32	Default	0 (OFF)
Slot 2	Pr 16.32	Range	0 (OFF) to 1 (ON)
Slot 3	Pr 17.32	Access	RW

Changes to the SM-CAN configuration in menu 15, 16 and 17 parameters will not take effect until the SM-CAN has been reset.

To reset an SM-CAN in slot 3:

1. Set Pr **MM.32** to ON.
2. When the reset sequence has been completed, Pr **MM.32** will be reset to OFF.
3. The SM-CAN will re-initialise using the updated configuration.

### NOTE

This sequence does NOT store the SM-CAN configuration parameters in the Unidrive SP or the SM-CAN FLASH memory.

## 5.5 Storing SM-CAN configuration parameters

<b>Name</b>	Store to SM-CAN FLASH memory		
<b>Slot 1</b>	Pr 15.31	<b>Default</b>	OFF
<b>Slot 2</b>	Pr 16.31	<b>Range</b>	OFF (0) to ON (1)
<b>Slot 3</b>	Pr 17.31	<b>Access</b>	RW

Menu 15, 16 and 17 parameters are stored in the drive. The SM-CAN will always use these values during initialisation to configure itself, so if a new SM-CAN is installed to the same slot, it will communicate using the same settings as the previous SM-CAN.

**NOTE** If the stored values in the drive are for a different type of Solutions Module, the drive will trip on "SLx.dF". The slot configuration parameters will be set to default values for SM-CAN, but the default values will NOT be stored in the drive.

The SM-CAN configuration parameters can also be stored in the FLASH memory on the SM-CAN. If the drive is replaced, the SM-CAN configuration parameters can subsequently be restored to the drive.

### 5.5.1 Saving drive parameters

To store drive parameters:

1. Set Pr **MM.00** to 1000.
2. Press the red RESET button.

The drive will store all parameters (except Menu 20) but the operation of the SM-CAN will not be affected. Changes made to the SM-CAN configuration parameters will not take effect until the SM-CAN is reset.

**NOTE** Drive parameters are NOT stored in the SM-CAN.

### 5.5.2 Storing parameters to SM-CAN FLASH memory

To store the SM-CAN configuration parameters in the FLASH memory in the SM-CAN in slot 3:

1. Set Pr **17.31** to ON.
2. Set Pr **MM.00** to 1000.
3. Press the red RESET button.

The drive will store its parameters, and CAN communication will be halted immediately. The SM-CAN configuration parameters will be saved within the SM-CAN FLASH memory. The SM-CAN will then reset and re-initialise using the updated configuration parameter values.

## 5.6 Reset all Solutions Modules

To reset all Solutions Modules installed on a drive:

1. Set Pr **MM.00** to 1070.
2. Press the red RESET button on the drive.

**NOTE** This sequence does NOT store the SM-CAN configuration parameters in the drive or the SM-CAN FLASH memory.

## 6 SM-CAN commands

SM-CAN has 14 CAN slots (slot 0 to 13) available for transmitting and receiving CAN frames from a CAN network. An additional slot (slot 14) may be used for receiving CAN frames only.

### 6.1 CAN slot and slot addressing

All SM-CAN commands must be given a target drive module slot and/or a target SM-CAN CAN slot. This is specified as MCC, and M and CC are detailed in Table 6.1.

**Table 6.1 Target Drive and SM-CAN slots**

Mnemonic	Specification	Range	Description
M	Drive module slot	0 to 3	Specifies the drive slot number where the target SM-CAN or SM-Applications is installed.
CC	CAN slot	0 to 14	Specifies the CAN slot in the target SM-CAN

If the target drive slot is set to 0, the SM-Applications will direct the CAN commands to the lowest drive slot that contains an SM-CAN. Similarly, the SM-CAN will direct any event task triggers to the lowest drive slot that contains an SM-Applications. This method is ideal if the drive is installed with one SM-CAN and one SM-Applications, as it guarantees that the CAN commands and event task triggers will be directed to the correct modules, irrespective of which slots the SM-CAN and SM-Applications are installed in.

**Table 6.2 Drive module slot destinations**

M	Description
0	All commands will be directed to the lowest drive slot containing an SM-CAN.
1	
2	All commands will be directed to the specified drive slot. If the slot does not contain an SM-CAN, the <code>status%</code> argument will indicate that the command was unsuccessful.
3	

If dual SM-CAN or SM-Applications are installed to the drive, it is important that all commands are directed to a specific drive slot. This ensures that all SM-CAN commands will be sent to the intended module, even if one of the SM-CAN modules has failed. If the target SM-CAN has failed for any reason, the `status%` argument for the command will indicate to the DPL program that the command was unsuccessful.

### 6.2 SYPT version

SYPT is required to program the SM-Applications with commands for the SM-CAN. SYPT V1.06.03 (or later) is required with DPLC2 Function Block Library V1.02.00 (or later) to provide full support for all SM-CAN commands.

## 6.3 PUTCAN

**PUTCAN** is used to transmit a CAN data frame, set a message filter for message reception, send a remote transmit request (RTR) frame, and configure the RTR response data frame.

**NOTE** If 2 transmit slots contain messages with identical CAN identifiers, the slot status information will get corrupted. It will be impossible to tell which slot actually attempted to transmit the message, and the actual transmission status that resulted.

DPL CODE

```
Status% = PUTCAN(CANSLOT%, Command%, CANID%, Length%, TxWord0%,
                  TxWord1%)
```

**Figure 6-1 Function block diagram**

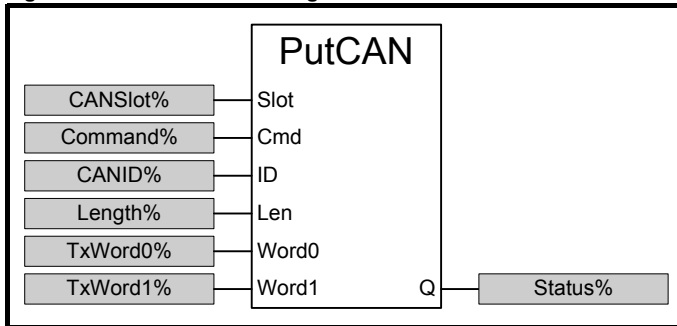

**Table 6.3 PUTCAN arguments**

Argument	Range	Description
CANSLOT%	0 to 313	Destination slot in the CAN controller, specified as MCC where: M = drive module slot containing target SM-CAN CC = CAN controller slot in target SM-CAN
Command%	0 to 3	Specifies the required command: 0 = transmit CAN frame 1 = configure mask for specified CAN slot 2 = send RTR message 3 = configure RTR response message
CANID%	0 to 2047	Specifies the 11bit CAN identifier
Length%	0 to 8	Specifies the number of data bytes to be sent in the CAN frame. Set to 0 when configuring a CAN slot mask or sending an RTR message
TxWord0%	$\pm 2^{31}$	Specifies the 32bit data word containing byte 0 (LSB) through to byte 3 (MSB) of the CAN data field. Unused bytes should be set to zero.
TxWord1%	$\pm 2^{31}$	Specifies the 32bit data word containing byte 4 (LSB) through to byte 7 (MSB) of the CAN data field. Unused bytes should be set to zero.
Status%	0 or 1	Returns the status code of the <b>PUTCAN</b> command, where: 0 = command failed 1 = command successfully completed

**NOTE** When **PUTCAN** returns a status code of 1, this indicates that the message was transferred successfully to the CAN controller. It does NOT indicate that the CAN message has been transmitted. Use **CANSTATUS** or **CANSTATUSALL** to check when the message has actually been transmitted.

## 6.4 GETCAN

**GETCAN** examines the specified message slot, and returns the CAN identifier, data length code and the data bytes. Unused data bytes will be set to 0.

DPL CODE

```
(Status%, Length%, RxWord0%, RxWord1%, TStamp%) =
                                GETCAN (CANSlot%)
```

**Figure 6-2 Function block diagram**

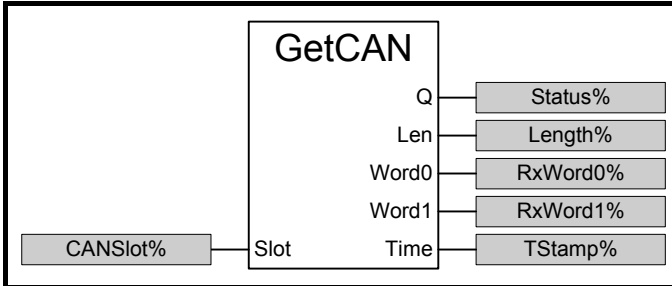

**Table 6.4 GETCAN arguments**

Argument	Range	Description
<b>CANSlot%</b>	0 to 314	Source slot in the CAN controller, specified as MCC where: M = drive module slot containing target SM-CAN CC = CAN controller slot in target SM-CAN
<b>Status%</b>	0 or 1	Returns the status code of the <b>GETCAN</b> command, where: 0 = command failed - slot is empty 1 = message read successfully - output arguments are valid
<b>Length%</b>	0 to 8	Returns the number of data bytes received in the CAN frame
<b>RxWord0%</b>	$\pm 2^{31}$	32bit data word containing bytes 0 (LSB) through 3 (MSB) of the CAN data field. Unused bytes will be set to zero
<b>RxWord1%</b>	$\pm 2^{31}$	32bit data word containing bytes 4 (LSB) through 7 (MSB) of the CAN data field. Unused bytes will be set to zero
<b>TStamp%</b>	0 to 255	8-bit time-stamp where a value of 1 represents approximately 32 bit periods. <b>TStamp%</b> should only be used to determine the order in which messages were received by the CAN controller

**NOTE** If 2 CAN slots are configured identical slot masks, any messages received for those slots will only appear in the lowest numbered slot. The higher numbered slot will never receive a message.

## 6.5 CANSTATUS

**CANSTATUS** returns the status of the specified message slot. For a receive slot, this will indicate if there is a message waiting to be processed, while for a transmit slot, it will indicate if the previous message has been transmitted or not.

DPL CODE

**Status%** = **CANSTATUS** (**CANSlot%**)

**Figure 6-3 Function block diagram**

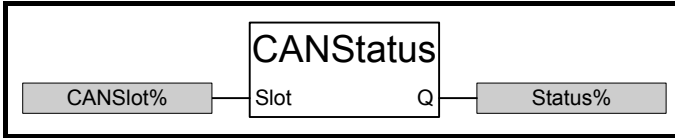

**Table 6.5 CANSTATUS arguments**

Argument	Range	Description
<b>CANSlot%</b>	0 to 314	Source slot in the CAN controller in the target SM-CAN, specified as MCC where: M = drive module slot containing target SM-CAN CC = CAN controller slot in target SM-CAN
<b>Status%</b>	0 to 2	Returns the status of the specified CAN slot in the target SM-CAN, where: 0 = slot is empty 1 = message transmission in progress 2 = new message has been received

## 6.6 CANSTATUSALL

**CANSTATUSALL** performs a similar function to **CANSTATUS**, but **CANSTATUSALL** will return the status of all CAN slots in the specified SM-CAN. **RxStatus%** indicates the slots with new received messages waiting, and **TxSlots%** indicates the slots with messages waiting to be transmitted.

**RxMask%** indicates that one or more slots are currently configured to receive CAN frames. SM-CAN will lose the slot mask settings when it is reset, so **RxMask%** allows the SM-Applications detect that SM-CAN has been reset, and re-configure the slot receive masks.

DPL CODE

```
(RxStatus%, TxStatus%, RxMask%) = CANSTATUSALL(ModuleSlot%)
```

**Figure 6-4** Function block diagram

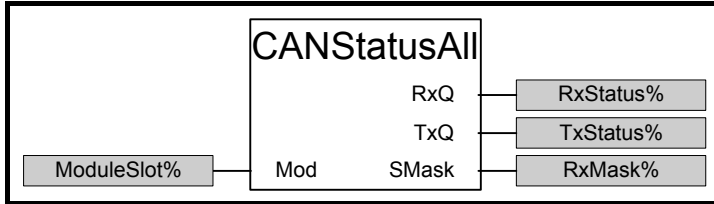

**Table 6.6** CANSTATUSALL arguments

Argument	Range	Description
<b>ModuleSlot%</b>	0 to 3	Specifies the drive module slot containing the target SM-CAN
<b>RxStatus%</b>	0 to 32767	Bits 0 to 14 represent the receive status of CAN slots 0 to 14. Any bit set to 1 indicates that the corresponding CAN slot has received a new message, and it can be retrieved using the <b>GETCAN</b> command
<b>TxStatus%</b>	0 to 16383	Bits 0 to 13 represent the transmit status of CAN slots 0 to 13. (Slot 14 cannot be used to transmit messages.) Any bit set to 1 indicates that the corresponding CAN slot contains a message that is still waiting to be transmitted
<b>RxMask%</b>	0 or 1	Indicates that one or more slots are currently configured to receive CAN frames. SM-CAN will lose the slot mask settings when it is reset, so this argument allows the SM-Applications to detect when SM-CAN has been reset, and restore the slot mask settings

## 6.7 ENABLECANTRIPS

**ENABLECANTRIPS** specifies which CAN network errors detected by SM-CAN will cause the drive to trip.

DPL CODE

Status% = **ENABLECANTRIPS**(TripMode%)

**Figure 6-5** Function block diagram

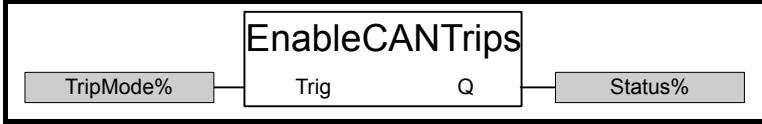

**Table 6.7** ENABLECANSTRIPS arguments

Argument	Range	Description
TripMode%	0 to 32	Specifies SM-CAN trip mode as MT, where: M = drive module slot containing target SM-CAN T = trip mode, where: 0 = CAN trips disabled 1 = drive trip only on bus-off error 2 = drive trip on bus-off error and no acknowledge
Status%	0 or 1	Returns the status of the <b>ENABLECANTRIPS</b> command, where: 0 = operation failed 1 = operation successful

## 6.8 RESETCANTIMER

**RESETCANTIMER** will reset the internal timer used to generate the **Tstamp%** argument in **GETCAN** to 0.

DPL CODE

Status% = **RESETCANTIMER**(Reset%)

**Figure 6-6** Function block diagram



**Table 6.8** RESETCANTIMER arguments

Argument	Range	Description
Reset%	0 to 31	Reset CAN timer as MR, where: M = drive module slot containing target SM-CAN R = reset, where: 0 = no action 1 = reset CAN timer
Status%	0 or 1	Returns the status of the <b>RESETCANTIMER</b> command, where: 0 = operation failed 1 = operation successful



## 6.9 CANSETUP

**CANSETUP** can be used to set the configuration parameters for the drive slot where an SM-CAN is installed. **CANSETUP** will disable the SM-CAN before changing configuration parameters, and re-enable using the new configuration when complete. Use **CANREADY** to ensure that SM-CAN has completed the re-initialisation sequence.

DPL CODE

```
Status% = CANSETUP(NodeID%, DataRate%, OWEnable%, ModuleSlot%)
```

**Figure 6-7 Function block diagram**

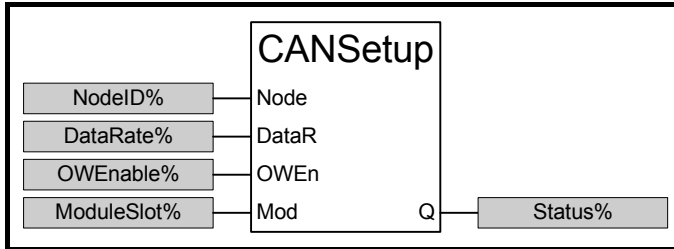

**Table 6.9 CANSETUP arguments**

Argument	Range	Description
NodeID%	0 to 127	Node address (Pr <b>MM.03</b> )
DataRate%	-2 to 8	Data rate (Pr <b>MM.04</b> )
OWEnable%	0 or 1	CAN slot over-write enable. Refer to section 9.4 <i>CAN slot over-write enable</i> on page 38 for full details
ModuleSlot%	0 to 3	Specifies the drive slot containing the target SM-CAN
Status%	0 or 1	Returns the status of the <b>CANSETUP</b> command, where: 0 = command failed 1 = command successful

**NOTE**

As **CANSETUP** automatically resets the SM-CAN to make the configuration changes take effect, it is strongly advised to call **CANSETUP** before **PUTCAN** is used to configure the receive slot masks.

## 6.10 CANGETNODEADDR

CANGETNODEADDR will return the node address parameter (Pr **MM.03**) for the specified SM-CAN. All CAN protocols will require some sort of node identification, and it is strongly recommended to use Pr **MM.03** for this purpose.

DPL CODE

```
(Status%, NodeID%) = CANGETNODEADDR (ModuleSlot%)
```

Figure 6-8 Function block diagram

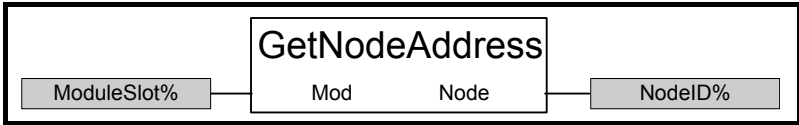

Table 6.10 GETNODEADDRESS arguments

Argument	Range	Description
ModuleSlot%	0 to 3	Specifies the drive slot containing the target SM-CAN
Status%	0 or 1	Returns the status of the CANGETNODEADDR command, where: 0 = command failed 1 = command successful
NodeID%	0 to 127	The specified SM-CAN node address

## 6.11 CANREADY

CANREADY should be used to check that the SM-CAN has completed the initialisation routine after power up. It should also be used to check if the CANSETUP or CANCONFIGEVENT commands have been completed.

DPL CODE

```
(Status%, Ready%) = CANREADY (ModuleSlot%)
```

Figure 6-9 Function block diagram

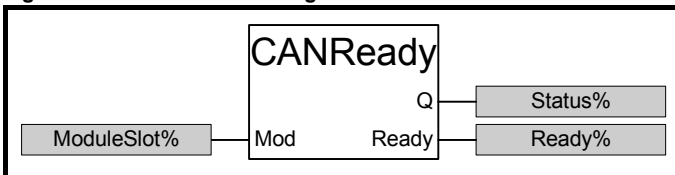

Table 6.11 CANREADY arguments

Argument	Range	Description
ModuleSlot%	0 to 3	Specifies the drive module slot containing the target SM-CAN
Status%	0 or 1	Returns the status of the CANREADY command, where: 0 = command failed 1 = command successful
Ready%	0 or 1	Indicates if the previous CANSETUP has completed or not. 0 = re-initialisation still in progress 1 = initialisation complete

## 6.12 CANCONFIGEVENT

SM-CAN can trigger an event task in an SM-Applications (or second processor) when the specified CAN slot receives a message. **CANCONFIGEVENT** is used to configure an event task trigger link, and 3 separate event task trigger links may be defined for a single SM-CAN.

**NOTE** SM-CAN will retain all event task trigger settings when it is reset.

DPL CODE

```
Status% = CANCONFIGEVENT(CANSlot%, Trigger%, TaskNo%,
                          ModuleSlot%)
```

Figure 6-10 Function block diagram

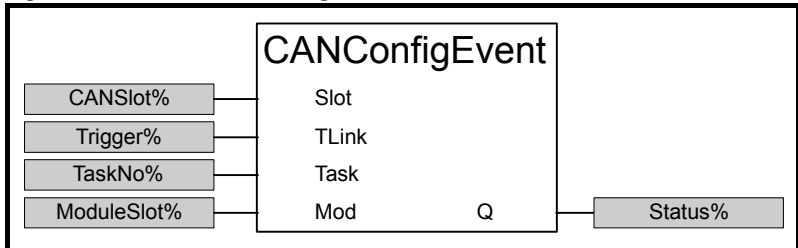

Table 6.12 CANCONFIGEVENT arguments

Argument	Range	Description
CANSlot%	0 to 314	Slot in the CAN controller that will trigger the specified event task when a message is received. Specified as MCC where: M = drive module slot containing target SM-CAN CC = CAN controller slot in target SM-CAN
Trigger%	1 to 3	Specifies the event task trigger link to be configured
TaskNo%	0 to 3	Specifies the event task to be triggered in the target SM-Applications, where: 0 = no event task (use to disable a previous configuration) 1 = EVENT 2 = EVENT1 3 = EVENT2 4 = EVENT3
ModuleSlot%	0 to 3	Specifies the drive module slot containing the SM-Applications whose event task is to be triggered
Status%	0 or 1	Returns the status of the <b>CANCONFIGEVENT</b> command, where: 0 = event task trigger configuration failed 1 = event task trigger configured successfully

**NOTE** As **CANCONFIGEVENT** automatically resets the SM-CAN to make the event task trigger active, it is strongly advised to call **CANCONFIGEVENT** before **PUTCAN** is used to configure the receive slot masks.

---

# 7 Using the SM-CAN commands

---

## 7.1 Configuring a CAN slot to receive messages

When a valid CAN frame is received from the CAN network, the 11-bit identifier is compared with the mask values for all receive slots. If a match is found, the data length code and data bytes will be placed in the corresponding slot. If no match is found, the frame is discarded. This allows frames to be filtered by the CAN controller in hardware, ensuring that only CAN frames intended for the local node are kept.

Use **PUTCAN** with the command argument set to 1. The example below shows how to configure CAN slot 8 to accept CAN frames with 11-bit identifier of 0x0D3. (211 decimal)  
DPL CODE

```
MaskStatus% = PUTCAN (8, 1, 0x0D3, 0, 0, 0)
```

**Figure 7-1 Function block diagram**

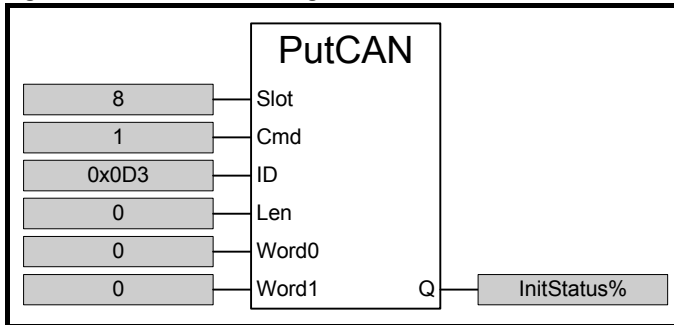

**NOTE**

A CAN slot will lose its mask value if it is subsequently used to transmit a message, so the slot mask must be re-configured before any new messages will be received. While this does not cause a problem for the CAN controller, it may be difficult to keep track in the controlling software of which slots are being used for which purpose. Usually, it is best to dedicate CAN slots to receive certain CAN frames, and use remaining slots for transmitting CAN frames.

## 7.2 Transmitting a CAN frame

`PUTCAN` can be used to configure a CAN frame and transfer it to the specified CAN slot to await transmission. The CAN controller will automatically handle network arbitration, and will transmit the message when it gains control of the CAN network. If SM-CAN has 2 or more messages waiting to be transmitted, it will attempt to transmit the message with the highest priority (i.e. lowest CAN identifier) first.

The example below shows how to transmit a CAN frame from slot 2 with CAN identifier 0x0D3 (211 decimal) and 2 data bytes containing the value in Pr 18.11.

DPL CODE

```
TxStatus% = PUTCAN(2, 0, 0x0D3, 2, #18.11, 0)
```

Figure 7-2 Function block diagram

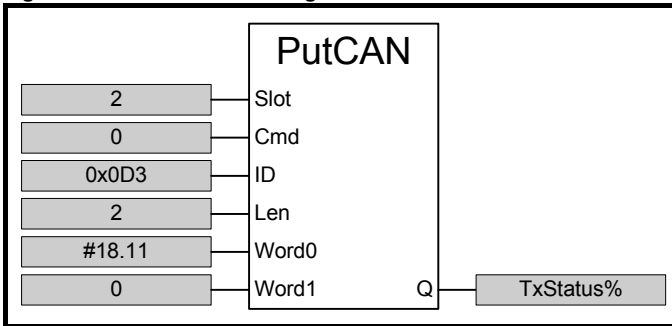

`TxStatus%` will indicate if the message was successfully transferred to the SM-CAN, but this does NOT mean that the message has actually been transmitted. `CANSTATUS` or `CANSTATUSALL` must be used to check when the message has actually been transmitted.

### 7.3 Receiving a CAN frame

SM-CAN does not notify the SM-Applications (or second processor) when new messages have arrived. SM-Applications must use **CANSTATUS** or **CANSTATUSALL** to see any new messages have arrived, and **GETCAN** to retrieve the data from any slot containing a message.

The example below shows how to use **CANSTATUS** to check for a new message in slot 8, and call **GETCAN** to retrieve the message if a new message is present.

DPL CODE

```
if CANSTATUS(8) = 2 then (RxStatus%, Length%, RxWord0%, RxWord1%,  
                        TStamp%) = GETCAN(8)
```

Figure 7-3 Function block diagram

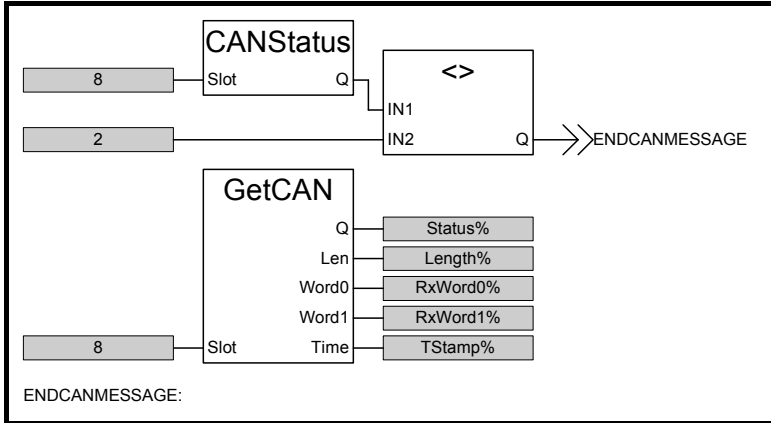

## 7.4 Remote transmit request (RTR)

The "remote transmit request" frame allows a node to request a data frame from another remote node. The remote node will return the RTR response frame. The RTR message has the RTR bit set to 1 (recessive) and contains no data bytes.

### 7.4.1 Requesting node

The requesting node must transmit an RTR frame from the slot that is to be used to receive the RTR response frame. The CAN identifier of the RTR frame MUST match the CAN identifier configured for the RTR response message in the remote node. In the example below, slot 3 will be used to transmit the RTR message.

DPL CODE

```
TxStatus% = PUTCAN(3, 2, 0x4D3, 0, 0, 0)
```

**Figure 7-4 Function block diagram**

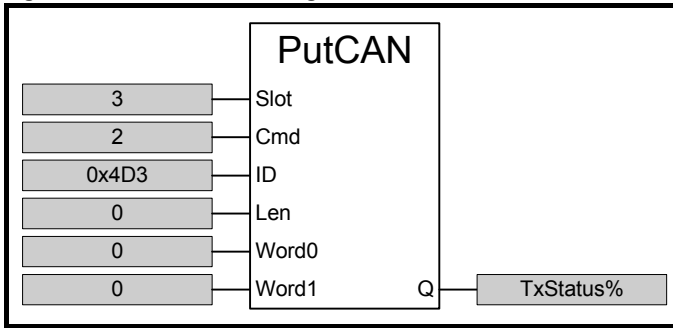

Use `CANSTATUS` to check the status of slot 3, and use `GETCAN` to retrieve the RTR response frame once it has been received (See section 6.5 `CANSTATUS` on page 22 and section 6.4 `GETCAN` on page 21).

## 7.4.2 Remote node

The remote node will automatically respond if the CAN identifier of the received RTR frame matches its own RTR CAN identifier. The RTR response frame can be placed in any of the slots reserved for transmitting data frames.

The SM-Applications can update the RTR response message at any time, provided it is not currently being transmitted. The RTR response is handled entirely by SM-CAN, and the SM-Applications will not know when an RTR response message has actually been transmitted.

Use the **PUTCAN** command with **Cmd%** set to 3 to update the CAN identifier, data length code and data bytes for the RTR response frame. In the example below, the RTR response will consist of 2 bytes containing the drive status word, and will be transmitted from slot 3.

DPL CODE

```
RTRStatus% = PUTCAN(1, 3, 0x4D3, 2, #10.40, 0)
```

**Figure 7-5 Function block diagram**

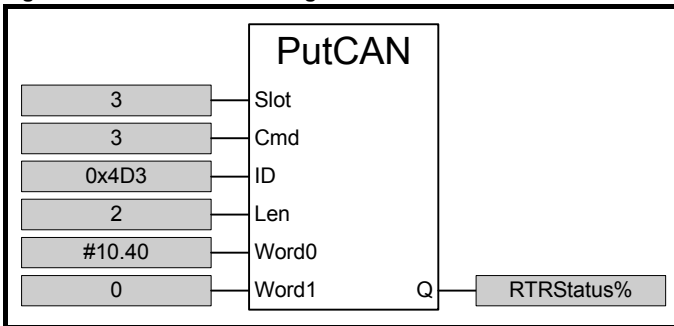



# 8 Diagnostics

The information from the parameters described below should always be noted before contacting Control Techniques for technical support.

## 8.1 Module ID code

Name	Module ID code		
Slot 1	Pr 15.01	Default	406
Slot 2	Pr 16.01	Range	406
Slot 3	Pr 17.01	Access	RO

The module ID code indicates the type of solutions module that is installed in the corresponding slot.

## 8.2 SM-CAN firmware version

Name	SM-CAN firmware - major version		
Slot 1	Pr 15.02	Default	N/A
Slot 2	Pr 16.02	Range	00.00 to 99.99
Slot 3	Pr 17.02	Access	RO

Name	SM-CAN firmware - minor version		
Slot 1	Pr 15.51	Default	N/A
Slot 2	Pr 16.51	Range	0 to 99
Slot 3	Pr 17.51	Access	RO

The full version of the SM-CAN firmware can be read for the corresponding slot. Table 8.1 shows how to construct the full firmware version from these values.

**Table 8.1 SM-CAN firmware version**

Major version	Minor version	Firmware version
1.01	5	V1.01.05

## 8.3 SM-CAN data rate

Name	SM-CAN data rate		
Slot 1	Pr 15.04	Default	5
Slot 2	Pr 16.04	Range	-2 to 8
Slot 3	Pr 17.04	Access	RW

Every node on a CAN network must be configured to run at the network data rate. If a node is configured with the wrong data rate, it may cause errors on the CAN network, and eventually trip on “SLx.Er” with error code (Pr **MM.50**) of 66. The SM-CAN must be reset to make a change of data rate take effect. If an invalid data rate is set, the SM-CAN will reject the configured data rate and revert to the default setting.

**Table 8.2 SM-CAN data rates**

Pr <b>MM.04</b>	bits/s	Pr <b>MM.04</b>	bits/s
-2	Disabled	4	125K
-1	Auto	5	100K
0	1.0M	6	50K
1	800K	7	20K
2	500K	8	10K
3	250K		

SM-CAN can be configured to automatically detect the CAN network data rate by setting Pr **MM.04** to -1. SM-CAN will monitor the CAN network, and set Pr **MM.04** to the correct value when detection is complete.

SM-CAN can also be disabled completely by setting Pr **MM.04** to -2. This ensures that a new default SM-CAN will not interfere with an existing network until it has been configured and enabled.

## 8.4 SM-CAN serial number

Name	SM-CAN serial number		
Slot 1	Pr 15.35	Default	N/A
Slot 2	Pr 16.35	Range	32 bit
Slot 3	Pr 17.35	Access	RO

Returns the last 6 digits of the 10-digit serial number on the part description label. This number is entered during manufacture of the SM-CAN, and cannot be changed.

## 8.5 CAN network status

<b>Name</b>	CAN network status		
<b>Slot 1</b>	Pr 15.06	<b>Default</b>	N/A
<b>Slot 2</b>	Pr 16.06	<b>Range</b>	-10 to 9999
<b>Slot 3</b>	Pr 17.06	<b>Access</b>	RO

Network activity can be monitored in the CAN network status parameter, Pr **MM.06**. When the SM-CAN is communicating successfully with the CAN master controller, the CAN network status will give an indication of the number of cyclic data messages per second that are being processed.

**Table 8.3 CAN network status codes**

Pr MM.06	Parameter	Description
>=0	Network ok	Indicates the number of CAN frames transmitted or received every second
-1	Initialised	No message acknowledgement received. Indicates that there are bad wiring connections on the network, or that SM-CAN is the only node currently active on the CAN network
-2	Internal hardware failure	Part of the SM-CAN initialisation sequence was not successful. If this fault persists after a power cycle, replace the SM-CAN
-3	Configuration error	There is an invalid setting in the SM-CAN configuration parameters
-4	Internal software error	Indicates that an internal software error has occurred. If this fault persists after a power cycle, replace the SM-CAN
-8	Auto data-rate detect	SM-CAN is currently attempting to automatically detect the network data rate
-10	Bus off error	SM-CAN has detected an excessive number of transmission errors and has entered the bus off condition

## 8.6 Drive trip display codes

If the SM-CAN detects an error during operation, it will force a trip on the drive. However, the trip code displayed on the drive will only indicate which slot initiated the trip. The exact reason for the trip will be indicated in the SM-CAN error code parameter, Pr **MM.50**.

Table 8.4 below shows the possible trip codes that will be displayed on the drive when a problem is detected with the SM-CAN, or when the SM-CAN initiates a trip.

**Table 8.4 Drive trip display codes**

Slot where trip was initiated			Fault	Description
Slot 1	Slot 2	Slot 3		
SL1.HF	SL2.HF	SL3.HF	Hardware fault	The drive has detected that a solutions module is present, but is unable to communicate with it. This trip will also occur if the SM-CAN is removed from the drive while it is powered up
SL1.tO	SL2.tO	SL3.tO	Watchdog timeout	Not used by SM-CAN
SL1.Er	SL2.Er	SL3.Er	Error	User trip generated by the SM-CAN
SL1.nF	SL2.nF	SL3.nF	Not installed	This trip will occur if a drive slot is configured for a SM-CAN, but a different module is installed in the slot. It will also occur if the SM-CAN has crashed
SL1.dF	SL2.dF	SL3.dF	Different module installed	The slot configuration parameters stored in the drive are not valid SM-CAN configuration parameters. This trip will also occur when an SM-CAN is installed to a previously un-used slot

**NOTE**

If the drive has V1.00.xx firmware installed, the SLx.nF trip will be seen if the SM-CAN is removed while the drive is powered up.

## 8.7 SM-CAN error codes

Name	SM-CAN error code		
Slot 1	Pr 15.50	Default	N/A
Slot 2	Pr 16.50	Range	0 to 255
Slot 3	Pr 17.50	Access	RO

If the SM-CAN detects an error during operation, it will force a trip on the drive, and update the SM-CAN error code, Pr **MM.50**. The table below shows the SM-CAN error codes.

**Table 8.5 SM-CAN error codes**

Error Code	Fault	Description
0	No error detected	Indicates that the trip was not caused by the SM-CAN. It is possible to trip the drive externally via various communication channels
66	Bus off error	The CAN controller has seen an excessive number of transmission errors, and has taken itself off the CAN network. (Refer to section 6.7 <i>ENABLECANTRIPS</i> on page 24)
69	No acknowledgement	No ACK bit was seen when the last message was transmitted. Indicates that there are no other devices on the network, or the SM-CAN is transmitting corrupt messages. (Refer to section 6.7 <i>ENABLECANTRIPS</i> on page 24)
70	FLASH transfer error	The SM-CAN was unable to upload the configuration parameters from its FLASH memory to the drive
74	SM-CAN module overtemperature	If the temperature inside the SM-CAN exceeds 82°C, the SM-CAN will trip the drive, and show error code 74
80	Inter-option communication error	Communications time-out has occurred, but SM-CAN is unable to determine the reason for the error
81	Communication error to slot 1	Direct communications between the SM-CAN and an SM-Applications in another slot has timed out. This can occur when the SM-CAN attempts to trigger an event task in an SM-Applications, and gets no response
82	Communication error to slot 2	
83	Communication error to slot 3	
98	Internal watchdog error	Internal error. Cycle power to the drive to reset from this trip. If trip persists, replace the SM-CAN
99	Internal software error	

# 9 Advanced features

## 9.1 Triggering SM-Applications event tasks

SM-CAN can be configured to trigger an event task in an SM-Applications (or second processor) when a message is received in a specific CAN slot. Up to 3 slots can be used to trigger event tasks in the SM-Applications. If 2 SM-Applications are installed, the target SM-Applications can also be specified.

Full details about configuring SM-CAN event task triggers can be found in section 6.12, *CANCONFIGEVENT* on page 27.

## 9.2 Restore SM-CAN defaults

Restore SM-CAN defaults			
<b>Slot 1</b>	Pr <b>15.30</b>	<b>Default</b>	OFF (0)
<b>Slot 2</b>	Pr <b>16.30</b>	<b>Range</b>	OFF (0) or ON (1)
<b>Slot 3</b>	Pr <b>17.30</b>	<b>Access</b>	RW

If the SM-CAN detects that the drive has been restored to default values, it will over-write the slot configuration parameters with the SM-CAN default values.

**NOTE** If the stored values in the drive are for a different type of Solutions Module, the SM-CAN will trip "SLx.DF", but no error code will be set. It will over-write the parameter values with the SM-CAN default values, but will NOT store these values in the drive.

Pr **MM.30** specifies whether the default values should be written to the SM-CAN FLASH memory. If Pr **MM.30** is set to ON, the default values will be written into the SM-CAN FLASH memory.

The full sequence of events to restore default settings for a SM-CAN installed in slot 3 is as follows:

1. Set Pr **17.00** to 1233 to restore European defaults (1244 for USA defaults) to the drive.
2. CAN communications will be stopped.
3. The drive will load and store its default parameter values.
4. Default parameter values for the SM-CAN will be loaded in Pr **17.PP** parameters.
5. If Pr **17.30** is set to ON (1), the SM-CAN default parameter values will be stored in the SM-CAN FLASH memory.
6. The SM-CAN will reset and re-initialise using the default values.

## 9.3 Restore previous SM-CAN configuration

Upload from SM-CAN FLASH memory			
<b>Slot 1</b>	Pr <b>15.33</b>	<b>Default</b>	OFF (0)
<b>Slot 2</b>	Pr <b>16.33</b>	<b>Range</b>	OFF (0) or ON (1)
<b>Slot 3</b>	Pr <b>17.33</b>	<b>Access</b>	RW

If valid configuration parameters have previously been stored in the SM-CAN FLASH memory, these values can be restored to the drive. When the configuration parameter values have been uploaded to the drive, the SM-CAN will reset and re-configure using the updated parameter values.

This feature allows a pre-configured SM-CAN to be installed to a drive without losing the SM-CAN configuration.

**NOTE** If the SM-CAN is unable to upload the configuration parameters to the drive, or configuration parameters have never been stored in the SM-CAN FLASH memory, the drive will trip “SLx.ER” and set the error code (Pr **MM.49**) to 70.

When Pr **MM.33** is set to ON, the SM-CAN will transfer the configuration parameters from its FLASH memory to the drive, over-writing the existing values in the drive.

The full sequence of events for restoring values from a SM-CAN installed in slot 3 is as follows:

1. Set Pr **17.33** to ON.
2. CAN communications will be stopped.
3. The SM-CAN will overwrite all Pr **17.PP** parameters with the values stored in its internal FLASH memory.
4. Pr **17.33** will be reset to OFF.
5. The SM-CAN will reset and re-initialise using the restored values.

This procedure will NOT store the updated drive parameters.

**NOTE** The SM-CAN will restore its configuration parameters to the menu of parameters associated with the slot that it is installed in. If an SM-CAN is moved from slot 3 on a drive, it can be re-installed in any slot on another drive.

## 9.4 CAN slot over-write enable

Name	CAN slot over-write enable		
Slot 1	Pr <b>15.36</b>	Default	OFF (0)
Slot 2	Pr <b>16.36</b>	Range	OFF (0) or ON (1)
Slot 3	Pr <b>17.36</b>	Access	RW

This parameters specifies how the SM-CAN behaves if a receive CAN slot already contains a message when a new message arrives for that slot. By default, SM-CAN discard the new message, and leave the existing message in the CAN slot for the SM-Applications (or second processor) to retrieve.

CAN slot over-write enable configures the SM-CAN such that the new message will over-write the old message in the CAN slot.

**Table 9.1 CAN slot over-write enable settings**

Pr <b>MM.36</b>	Setting	Description
OFF (0)	Discard	The old message waiting in the CAN slot will be left intact, and the new message will simply be discarded
ON (1)	Over-write	The old message currently waiting in the CAN slot will be over-written with the new message

# 10 Quick reference

## 10.1 Complete parameter reference

Table 10.1 shows every parameter available in the drive for configuring the SM-CAN, plus a cross-reference to the section in the manual where more information can be found.

**Table 10.1 SM-CAN parameter reference**

Slot 1	Slot 2	Slot 3	Default	Cross reference	Description
Pr 15.01	Pr 16.01	Pr 17.01	406	Section 8.1 on page 33	Module ID code
Pr 15.02	Pr 16.02	Pr 17.02	----	Section 8.2 on page 33	Major firmware version
Pr 15.03	Pr 16.03	Pr 17.03	0	Section 5.1 on page 15	Node address
Pr 15.04	Pr 16.04	Pr 17.04	-2	Section 5.2 on page 16	Data rate
Pr 15.06	Pr 16.06	Pr 17.06	----	Section 8.5 on page 35	Network operating status
Pr 15.30	Pr 16.30	Pr 17.30	OFF (0)	Section 9.2 on page 37	Restore SM-CAN defaults
Pr 15.31	Pr 16.31	Pr 17.31	OFF (0)	Section 5.5 on page 18	Store to SM-CAN FLASH memory
Pr 15.32	Pr 16.32	Pr 17.32	OFF (0)	Section 5.4 on page 17	Reset SM-CAN
Pr 15.33	Pr 16.33	Pr 17.33	OFF (0)	Section 9.3 on page 37	Restore previous configuration from SM-CAN FLASH memory
Pr 15.35	Pr 16.35	Pr 17.35	----	Section 8.4 on page 34	Serial number
Pr 15.36	Pr 16.36	Pr 17.36	OFF (0)	Section 9.4 on page 38	CAN slot over-write enable
Pr 15.50	Pr 16.50	Pr 17.50	----	Section 8.7 on page 36	SM-CAN error codes
Pr 15.51	Pr 16.51	Pr 17.51	----	Section 8.2 on page 33	Minor firmware version

---

# Index

---

<b>B</b>	
Back-up power supply .....	14
<b>C</b>	
Cable shield connections .....	12
CAN cable .....	10
CAN ground point .....	13
CAN slot over-write enable .....	38
CANCONFIGEVENT .....	27
CANGETNODEADDR .....	26
CANREADY .....	26
CANSETUP .....	25
CANSTATUS .....	22
CANSTATUSALL .....	23
Cautions .....	5
Commands .....	19
Compliance .....	6
Configuring a CAN slot .....	28
Connections .....	10
<b>D</b>	
Data rate .....	16, 34
Data rates .....	34
Diagnostics .....	33
Dual SM-CAN .....	19
<b>E</b>	
Electrical safety .....	5
ENABLECANTRIPS .....	24
Environmental limits .....	6
<b>F</b>	
Fail-safe mechanical brake .....	6
Firmware version .....	33
Fitting .....	8
<b>G</b>	
GETCAN .....	21
Grounding bar .....	13
<b>I</b>	
Installation .....	8
<b>M</b>	
Maximum network length .....	14
Module ID code .....	33
Motor .....	6



<b>N</b>	
Network status .....	17, 35
Network status codes .....	17, 35
Node address .....	15
Notes .....	5
<b>P</b>	
Parameter reference .....	39
Parameters .....	6
Parameters - adjusting .....	6
PUTCAN .....	20, 29
<b>Q</b>	
Quick reference .....	39
<b>R</b>	
Receiving a CAN frame .....	30
Regulations .....	6
Remote node .....	32
Remote transmit request (RTR) .....	31
Reset all .....	18
RESETCANTIMER .....	24
Resetting .....	17
Restore previous SM-CAN configuration .....	37
Restore SM-CAN defaults .....	37
<b>S</b>	
SAFE TORQUE OFF (SECURE DISABLE) .....	5
Safety of personnel .....	5
Safety standards .....	5
Safety-related functions .....	5
Saving .....	18
Serial number .....	34
Slot addressing .....	19
SM-CAN error codes .....	36
Specification .....	7
Status% .....	19
STOP .....	5
Storing .....	18
SYPT version .....	19
System design .....	5
<b>T</b>	
Terminal descriptions .....	9
Termination .....	11
Transmitting a CAN frame .....	29
Triggering SM-Applications event tasks .....	37
Trip display codes .....	35
<b>W</b>	
Warnings .....	5



**0471-0023-02**